



# Standard Guide for Procedure for Measuring Ionizing Radiation-Induced Attenuation in Silica-Based Optical Fibers and Cables for Use in Remote Fiber-Optic Spectroscopy and Broadband Systems<sup>1</sup>

This standard is issued under the fixed designation E1614; the number immediately following the designation indicates the year of original adoption or, in the case of revision, the year of last revision. A number in parentheses indicates the year of last reapproval. A superscript epsilon ( $\epsilon$ ) indicates an editorial change since the last revision or reapproval.

## 1. Scope

1.1 This guide covers a method for measuring the real time, in situ radiation-induced spectral attenuation of multimode, step index, silica optical fibers transmitting unpolarized light. This procedure specifically addresses steady-state ionizing radiation (that is, alpha, beta, gamma, protons, etc.) with appropriate changes in dosimetry, and shielding considerations, depending upon the irradiation source.

1.2 This test procedure is not intended to test the balance of the optical and non-optical components of an optical fiber-based system, but may be modified to test other components in a continuous irradiation environment.

1.3 The values stated in SI units are to be regarded as standard. No other units of measurement are included in this standard.

1.4 *This standard does not purport to address all of the safety concerns, if any, associated with its use. It is the responsibility of the user of this standard to establish appropriate safety and health practices and determine the applicability of regulatory limitations prior to use.*

## 2. Referenced Documents

2.1 Test or inspection requirements include the following references:

### 2.2 *Military Standard:*<sup>2</sup>

[MIL-STD-2196-\(SH\) Glossary of Fiber Optic Terms](#)

<sup>1</sup> This guide is under the jurisdiction of ASTM Committee E13 on Molecular Spectroscopy and Separation Science and is the direct responsibility of Subcommittee E13.09 on Fiber Optics, Waveguides, and Optical Sensors.

Current edition approved Jan. 1, 2013. Published January 2013. Originally approved in 1994. Last previous edition approved in 2004 as E1614 – 94 (2004). DOI: 10.1520/E1614-94R13.

<sup>2</sup> Available from Standardization Documents Order Desk, Bldg. 4 Section D, 700 Robbins Ave., Philadelphia, PA 19111-5094, Attn: NPODS. Available from Standardization Documents Order Desk, DODSSP, Bldg. 4, Section D, 700 Robbins Ave., Philadelphia, PA 19111-5098, <http://dodssp.daps.dla.mil>.

### 2.3 *EIA Standards:*<sup>3</sup>

[EIA-455-57 Optical Fiber End Preparation and Examination](#)

[EIA-455-64 Procedure for Measuring Radiation-Induced Attenuation in Optical Fibers and Cables](#)

[EIA-455-78A-90 Spectral Attenuation Cutback Measurement for Single-Mode Optical Fibers](#)

## 3. Terminology

### 3.1 *Definitions:*

3.1.1 Refer to MIL-STD-2196 for the definition of terms used in this guide.

## 4. Significance and Use

4.1 Ionizing environments will affect the performance of optical fibers/cables being used to transmit spectroscopic information from a remote location. Determination of the type and magnitude of the spectral attenuation or interferences, or both, produced by the ionizing radiation in the fiber is necessary for evaluating the performance of an optical fiber sensor system.

4.2 The results of the test can be utilized as a selection criteria for optical fibers used in optical fiber spectroscopic sensor systems.

NOTE 1—The attenuation of optical fibers generally increases when exposed to ionizing radiation. This is due primarily to the trapping of radiolytic electrons and holes at defect sites in the optical materials, that is, the formation of color centers. The depopulation of these color centers by thermal and/or optical (photobleaching) processes, or both, causes recovery, usually resulting in a decrease in radiation-induced attenuation. Recovery of the attenuation after irradiation depends on many variables, including the temperature of the test sample, the composition of the sample, the spectrum and type of radiation employed, the total dose applied to the test sample, the light level used to measure the attenuation, and the operating spectrum. Under some continuous conditions, recovery is never complete.

<sup>3</sup> Available from Electronic Industries Alliance (EIA), 2500 Wilson Blvd., Arlington, VA 22201, <http://www.eaus.org/eia>.

5. Apparatus

5.1 The test schematic is shown in Fig. 1. The following list identifies the equipment necessary to accomplish this test procedure.

5.2 *Light Source*—The light source should be chosen so that the spectral region of interest is provided. Lamps or globars, or both, may be used for analysis as long as they satisfy the power, stability, and system requirements defined. In general, the silica fibers should be evaluated from  $\approx 350$  to  $\approx 2100$  nm, therefore, more than one light source or multiple testing, or both, may be necessary.

5.3 *Shutter*—In order to determine the background stability, the light will have to be blocked from entering the optical fiber by a shutter.

5.4 *Focusing/Collection Optics*—A number of optical elements may be needed for the launch and collection of light radiation into/from the test optical fiber and other instrumentation (light source, spectrometer, detector). The minimal requirement for these elements shall be that the numerical aperture of the adjacent components are matched for efficient coupling.

5.5 *Mode Stripper*—High-order cladding modes must be attenuated by mode stripping, and mode stripping should occur prior to and after the radiation chamber, especially if the fiber length is shorter than that specified in this guide. If it is found that the coating material effectively strips the cladding modes from the optical fiber, then a mode stripper is not necessary.

5.6 *Light Radiation Filtering*—Filters may be necessary to restrict unwanted regions of the light spectrum. They may be needed to avoid saturation or nonlinearities of the detector and recording instrumentation by transient light sources (Cerenkov or other luminescence phenomena), or due to wide spectral power variances with the output of the broadband sources.

5.7 *Optical Splitter*—An optical splitter or fiber optic coupler shall divert some portion of the input light to a reference detector for monitoring the stability of the light source.

5.8 *Optical Interconnections*—The input and output ends of the optical fiber shall have a stabilized optical interconnection, such as a clamp, connector, splice, or weld. During an attenuation measurement, the interconnection shall not be changed or adjusted. If possible, the optical interconnections should not be within the irradiation region.

5.9 *Wavelength Demultiplexor*—A means of separating the spectral information must be used at the detector end of the system so that multiple wavelengths can be simultaneously evaluated (that is, grating, prism, Acousto-optic tunable filter, etc.).

5.10 *Optical Detection*—The optical detection system shall be wavelength calibrated in accordance with the manufacturer’s recommended procedure utilizing standard spectral line sources. The calibration and spectral response of the detection systems should be documented.

5.10.1 *Sample Detector*—An optical detector that is linear and stable over the range of intensities that are encountered shall be used. The method employed must be able to evaluate a wide spectral range rapidly (that is, 500 ms). The primary requirement of the detector is that the spectral detectivity corresponds to the spectral transmission of the light source/fiber system and that a spectral resolution of  $\pm 10$  nm is attainable.

5.10.2 *Reference Detector*—The reference detector is used for light source stability measurements for the wavelength range of interest. The reference detection system should have a similar response to the sample detection system. If an optical fiber splitter is used for the reference arm of the detection scheme, then the detection system must be able to accept the output from an optical fiber. If the detection scheme can

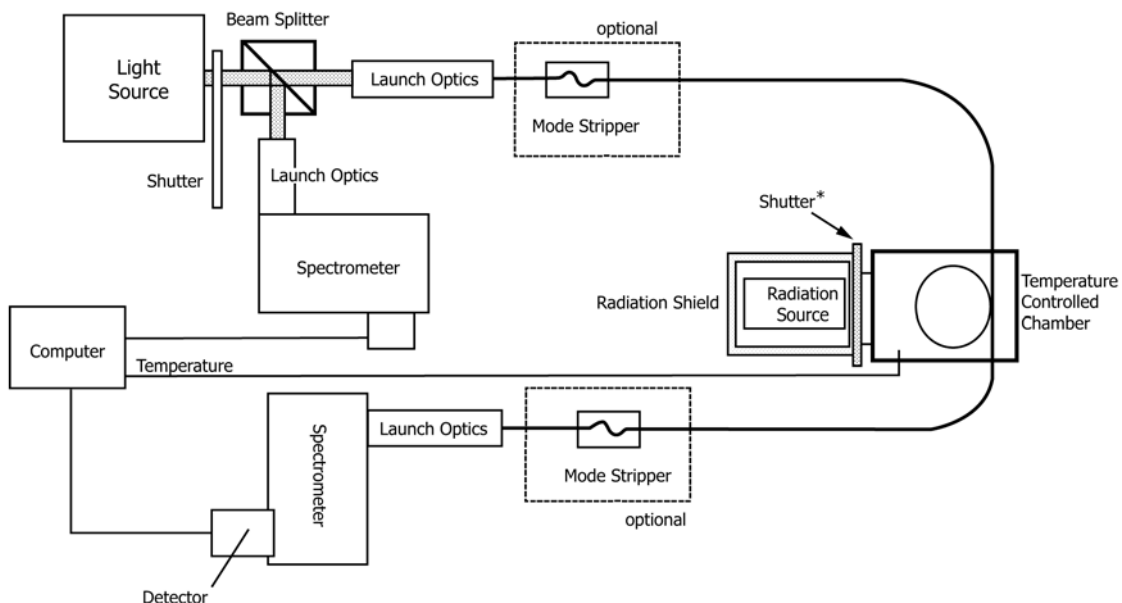

NOTE 1—If a shuttered source is not used, the test engineer must account for the placement and extraction of the test sample in the irradiator.

FIG. 1 Schematic Instrumentation Diagram